

CERES PENDANT

Installation Guide

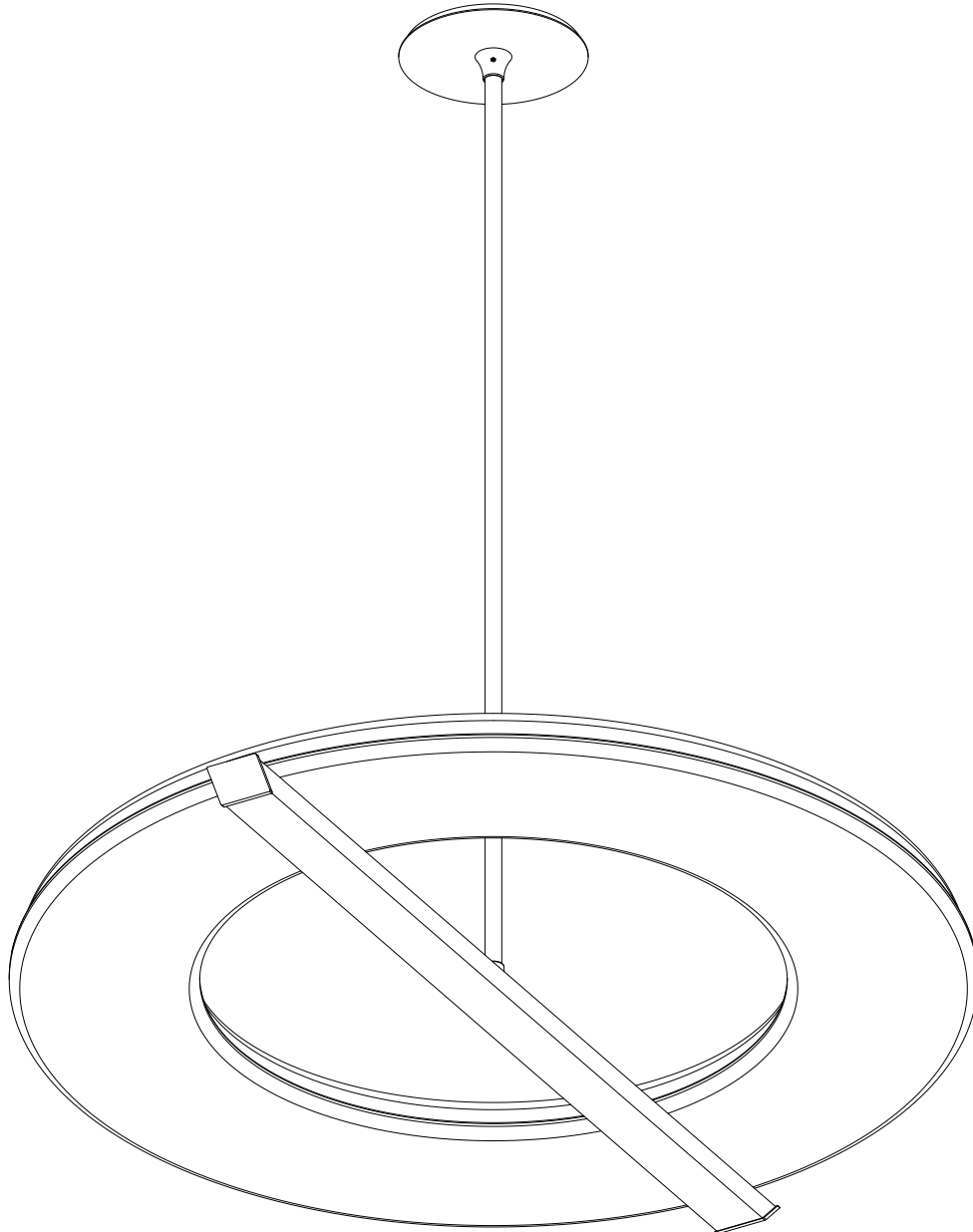

!

Please handle with care and wear gloves at all times during Assembly and installation to avoid damaging components.

TECHNICAL

Wattage
110W LED 2700k
(Dimmable)

Weight
30KG (66lbs)

PARTS & COMPONENTS

- A. Ceres Ring
- B. LED Driver
- C.1 Drop Rod (With Cover Plate)
- C.2 Flush Mounting Plate
- D.1 Drop Rod (With Ceiling Rose)
- D.2 Ceiling Mounting Plate and 6x M5 x 15mm Screws

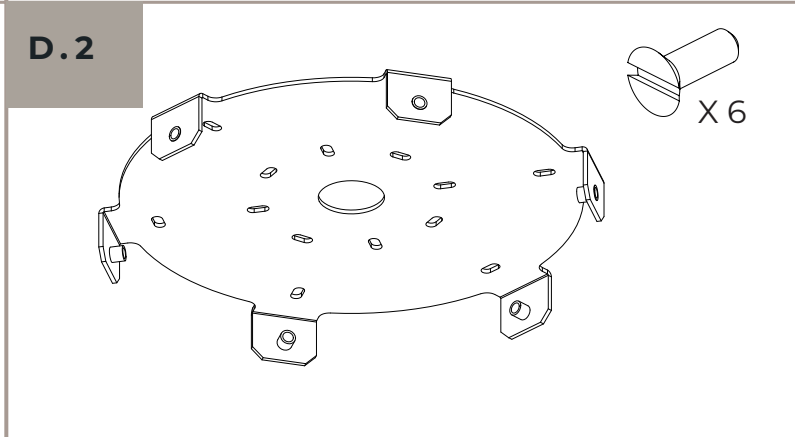
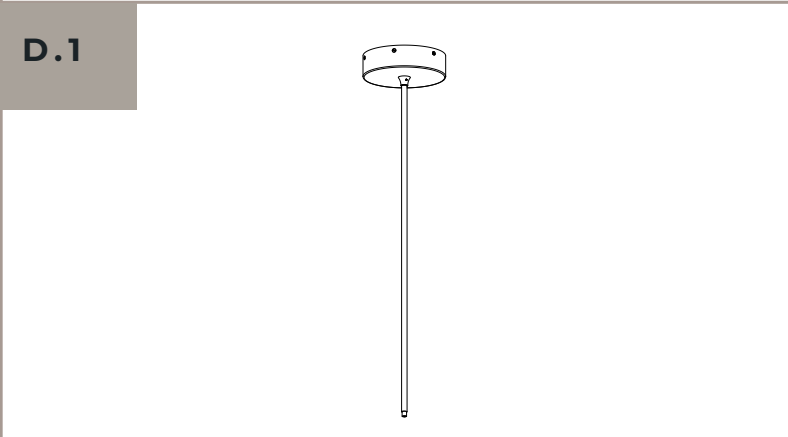
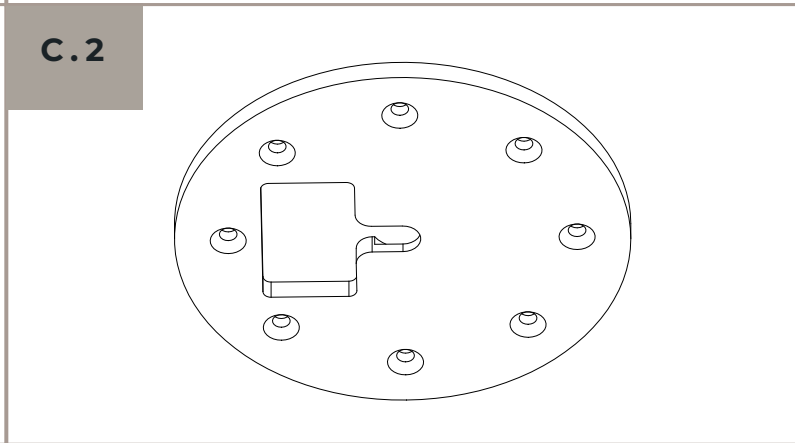
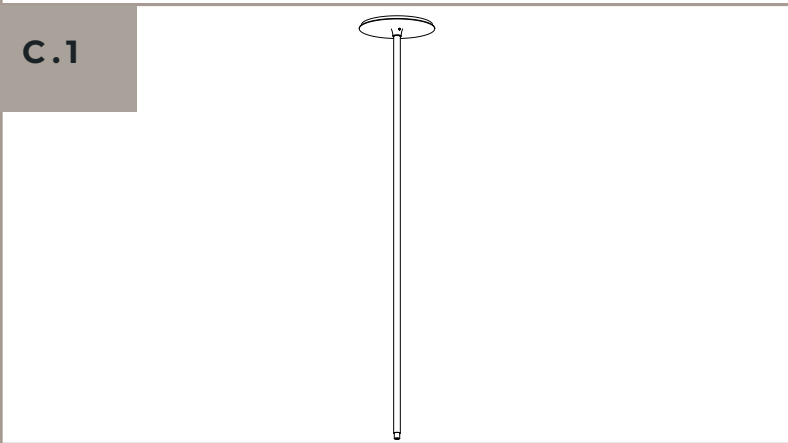
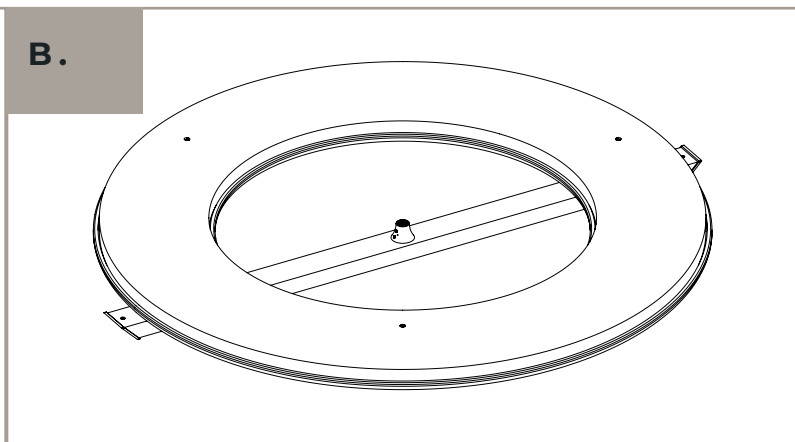
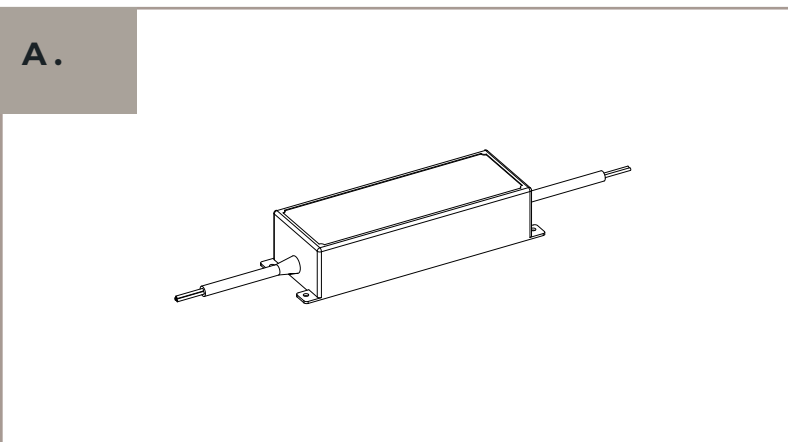

- All nuts and bolts required for assembling the light are included.



BEFORE INSTALLATION

- Check that you have all components before starting the installation.
 - Installation must be carried out by a qualified electrician.
 - A minimum of two people is required to install a pendant light.
- Check that the ceiling or wall fixings are suitable and strong enough to support the weight of the light fixture.
 - You will need the below specific tools for a successful installation.

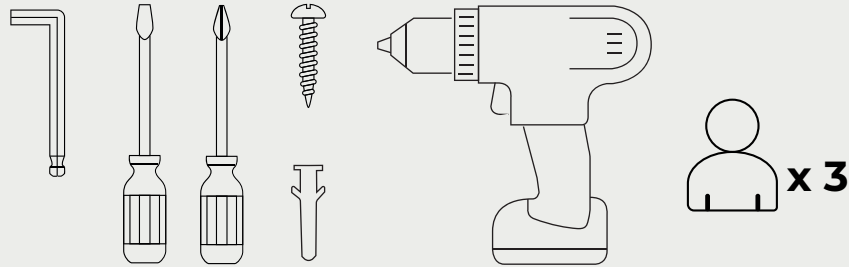

Warning: This product is heavy, please handle with care and use appropriate equipment where required.

IP20

The Ceres Pendant light is designed for use in dry indoor locations only. This product is unsuitable for wet and damp locations.



If the external flexible cable or cord of this luminaire is damaged, it shall be exclusively replaced by the manufacturer or his service agent or a similar qualified person in order to avoid a hazard.

This product is considered to be a “containing product” in the sense of Regulations (EU) 2019/2020 and (EU) 2019/2015.

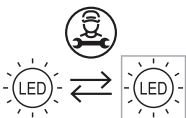

The LED light source contained in this luminaire shall only be replaced by the manufacturer or his service agent or a similar qualified person, must be of equal or higher energy rating. Full electrical, mechanical, thermal and optical functionality must be restored.

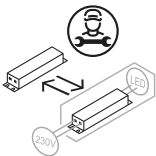

Control gear contained in this luminaire shall only be replaced by the manufacturer or his service agent or a similar qualified person.

Used electrical and electronic products should not be mixed with general household waste. For proper treatment, recovery and recycling, please take this product(s) to designated collection points where it will be accepted free of charge.



CTO Lighting is a member of the WEEE producer compliance scheme. Registration number: WEE/AG0005ZR

Remote Driver Installation

Please see table below for remote driver installation.

			Cable Thickness								
			0.5mm ²	0.75mm ²	1mm ²	1.5mm ²	2.5mm ²	4mm ²			
			20 AWG	18 AWG	17 AWG	15 AWG	13 AWG	11 AWG			
Drop Rod Length (M)	1	Max Cable Length	6 M	9 M	12 M	15M					
	2		5 M	8 M	10 M						
	3		4 M	7 M	9 M					13 M	
	4		4 M	6 M	8 M					11 M	
	5		3 M	5 M	6.5 M					9 M	
	6		2 M	4 M	5 M					7.5 M	13 M
	7		2 M	3 M	4 M					5.5 M	9 M
	8		1 M	2 M	2.5 M					3.5 M	6.5 M

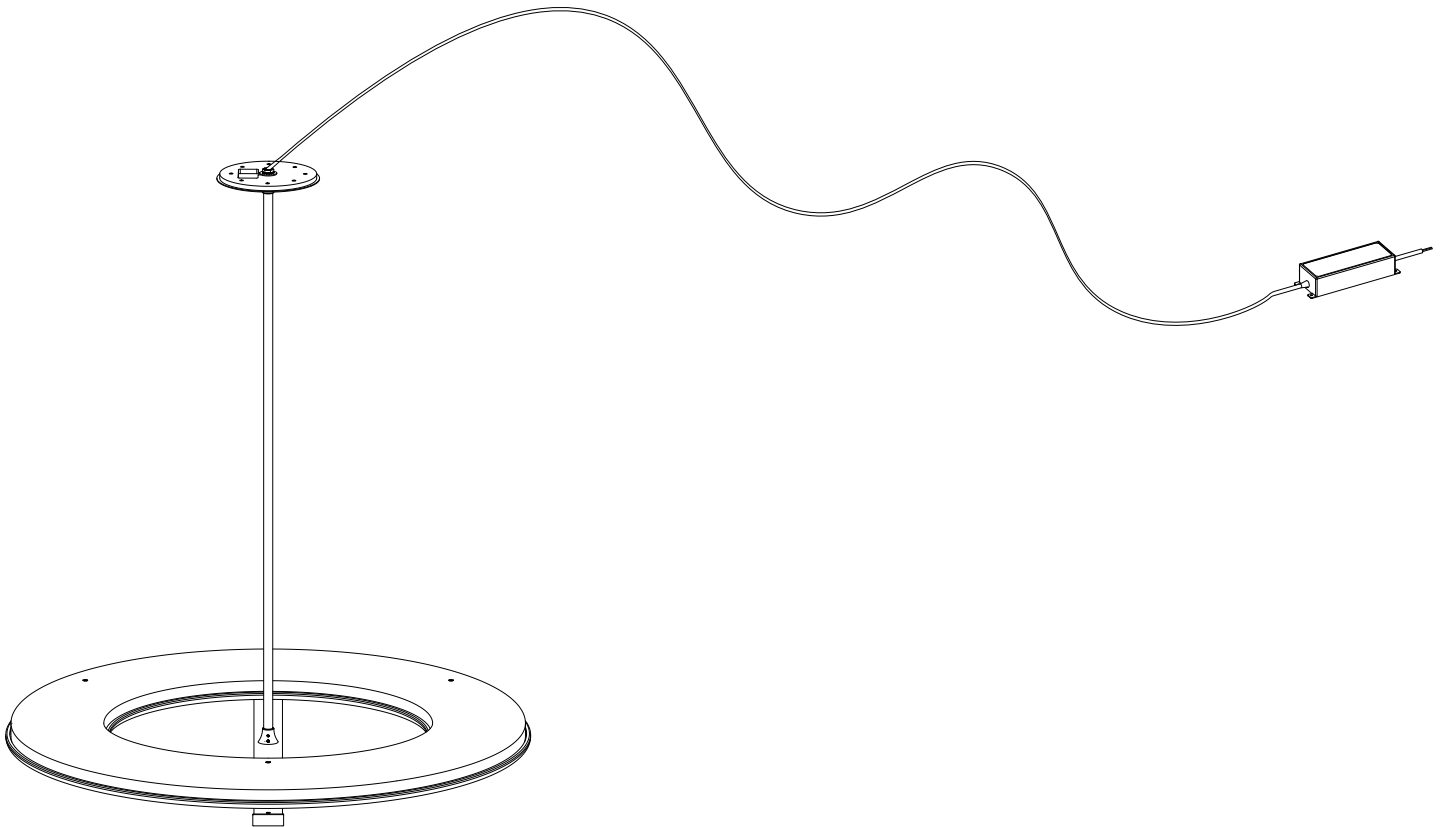

Packaging Removal

1. Open the Box and observe directional arrows

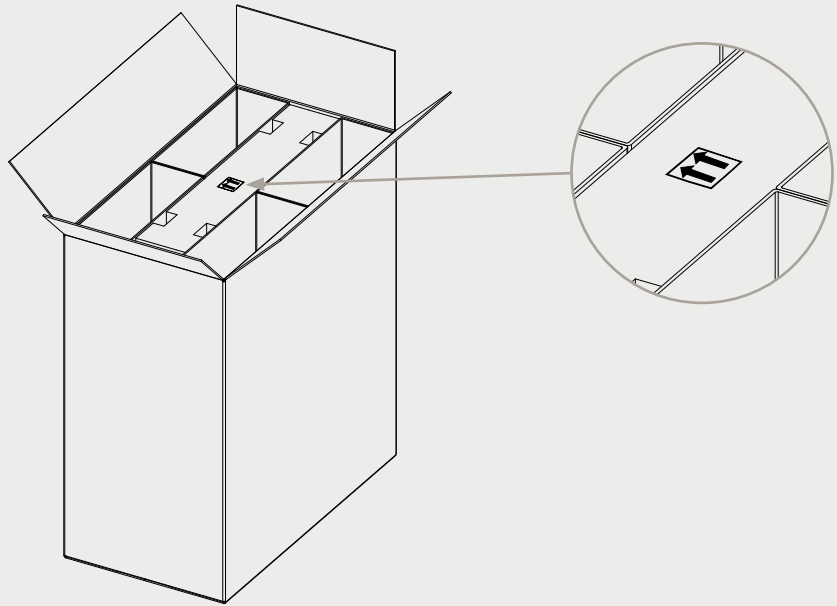

2. Lie the box on its long edge and remove from the box then lay flat facing the correct way upwards as indicated.

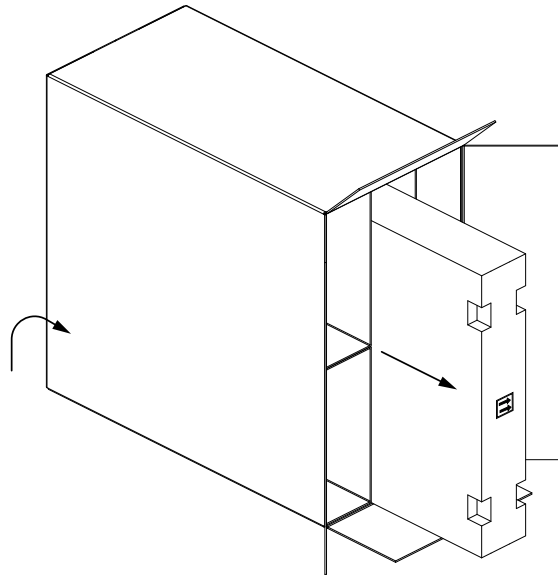

3. Remove the lid, centre circle and driver from the packaging.

 Keep the pendant in the packaging until advised

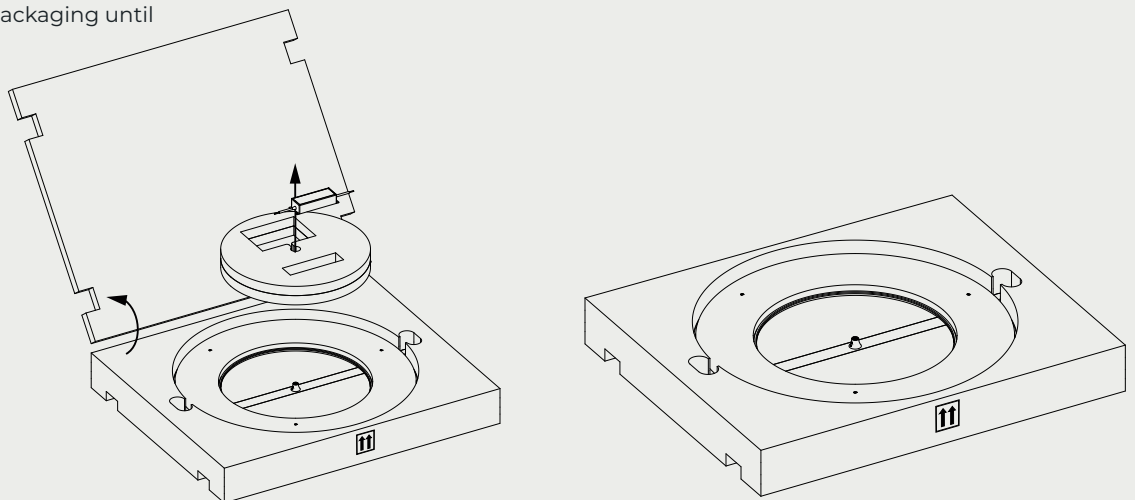

Flat Plate Installation

1. Do not Remove from base Packaging until advised. 

A. Feed Cable through the rod and then tighten the drop rod (B) into the centre of the Ring (A).

B. Then tighten the 2x upper grub screws at the base of the drop rod to lock it in place.

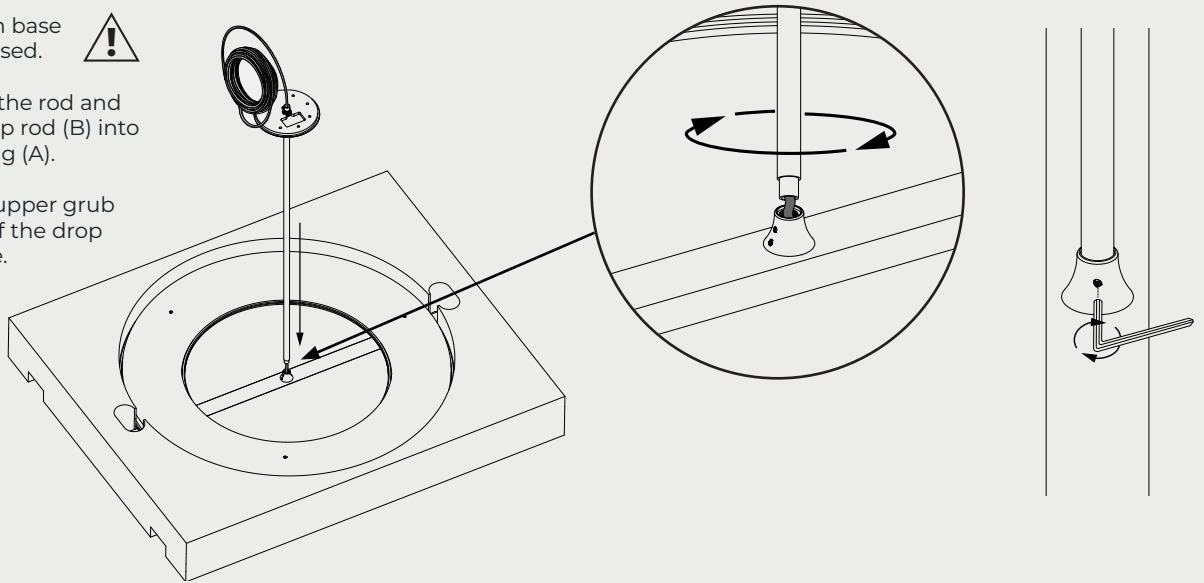

2. Cut 80mm hole for driver, in centre of fitting location. Make sure there is enough space in cavity for the LED driver. Do not cover driver with insulation, allow 160mm of clear air.

IMPORTANT: Driver can be NO more than 8M from the luminaire

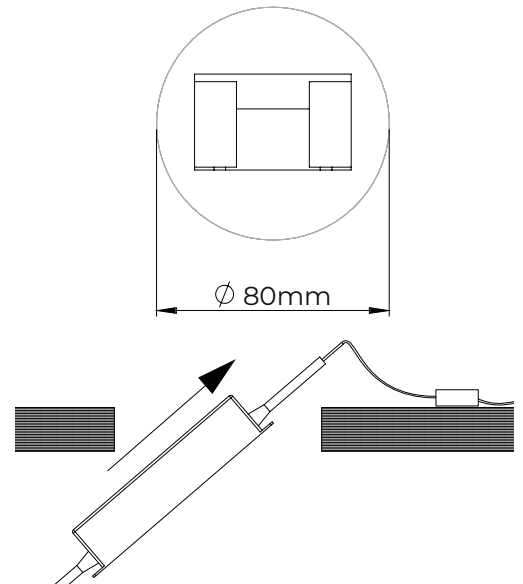
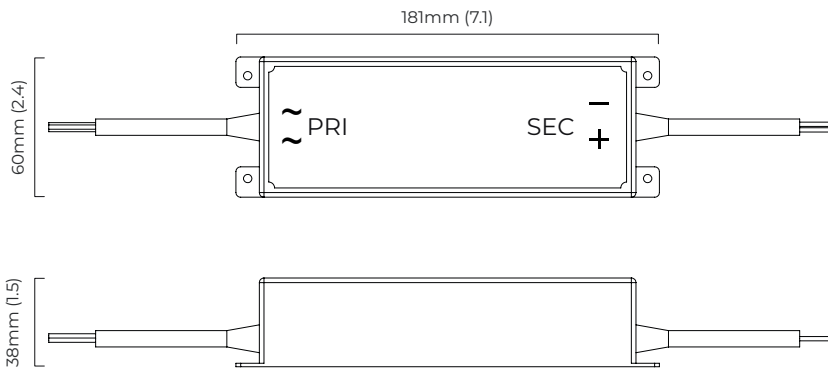

3. Loosen the grub screw holding the flat plate up and lower down the drop rod

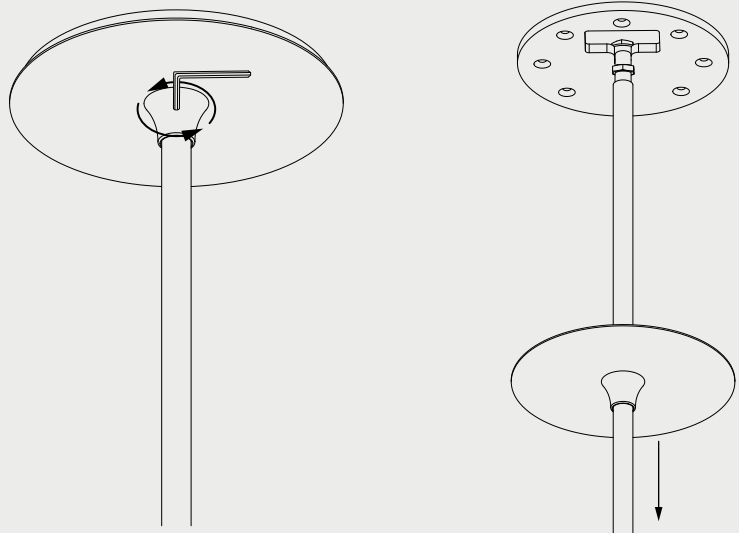

4. Remove the Flush Mounting Plate (C.2) from the drop rod by loosening the lower nut then lowering and sliding the plate to the side.

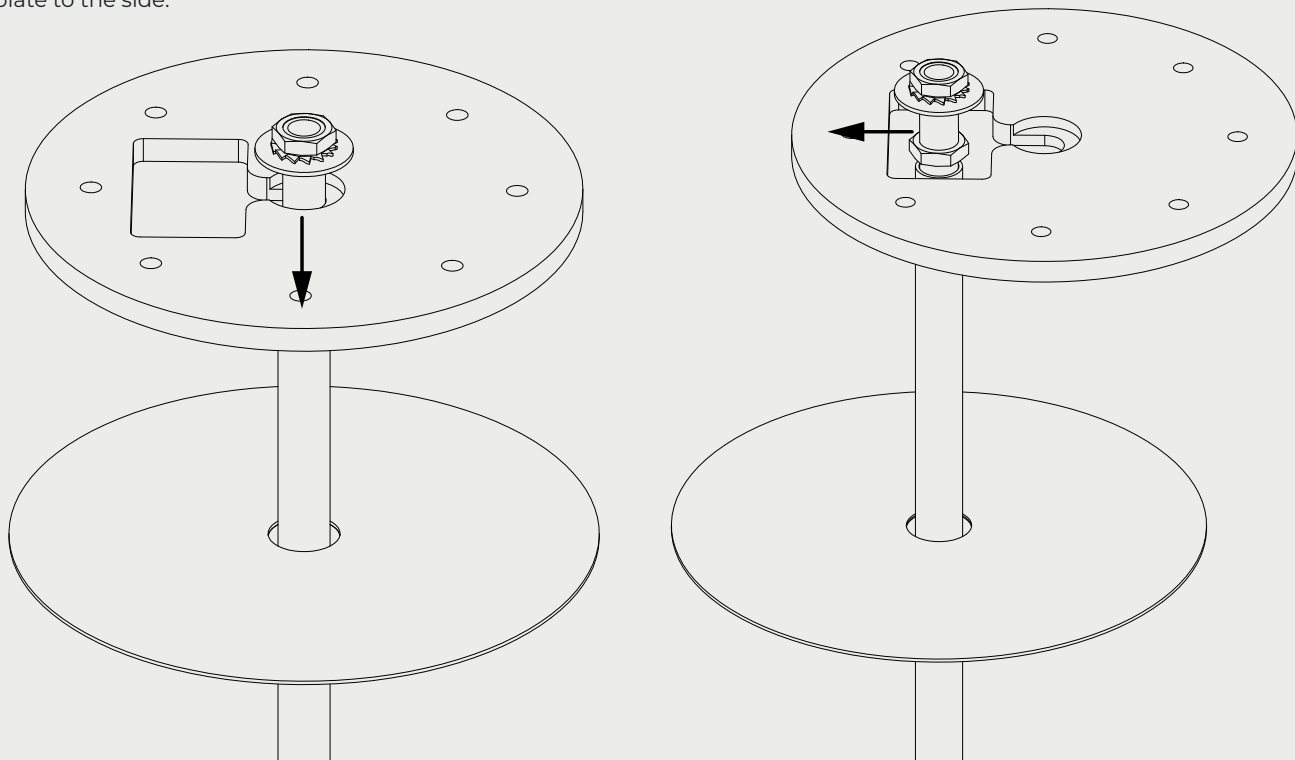

5. A) Securely fix the mounting plate to the ceiling in the correct position using fixings suitable for the surface you are mounting to (not supplied).
Ensure the hole allows clearance for the off centre cut out on the flat plate.
- B) Raise the pendant and make the electrical connections to the driver ensuring all wires are colour matched and the pendant is earthed correctly.

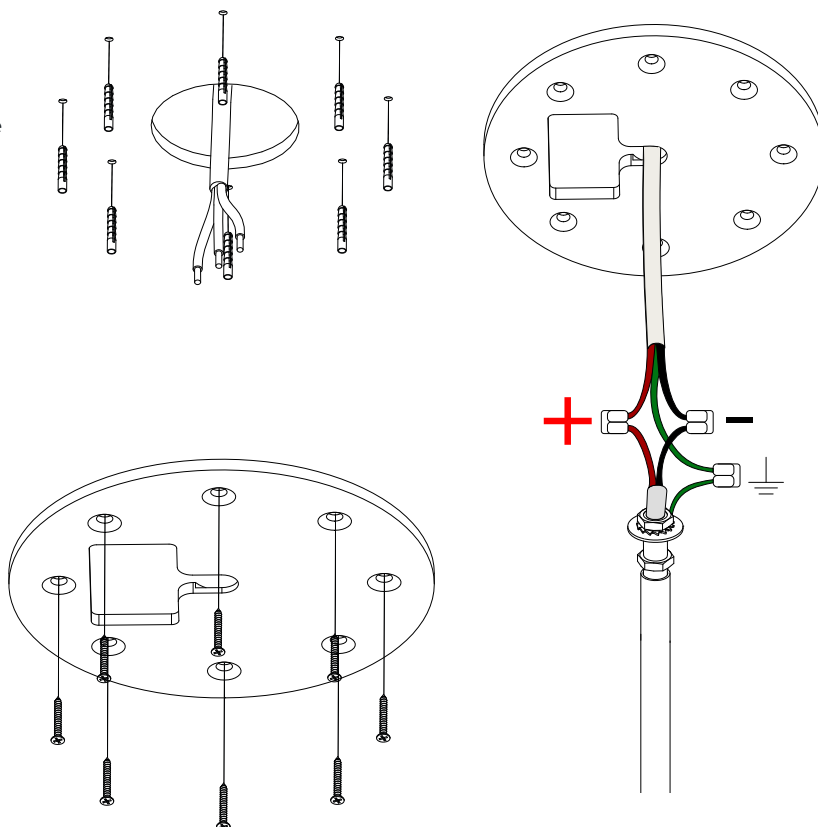

- 7.** Raise the pendant in the packaging base so it goes through the cut out on the flush plate.
Move to the rod to the centre and lower so it sits in the groove in the centre.

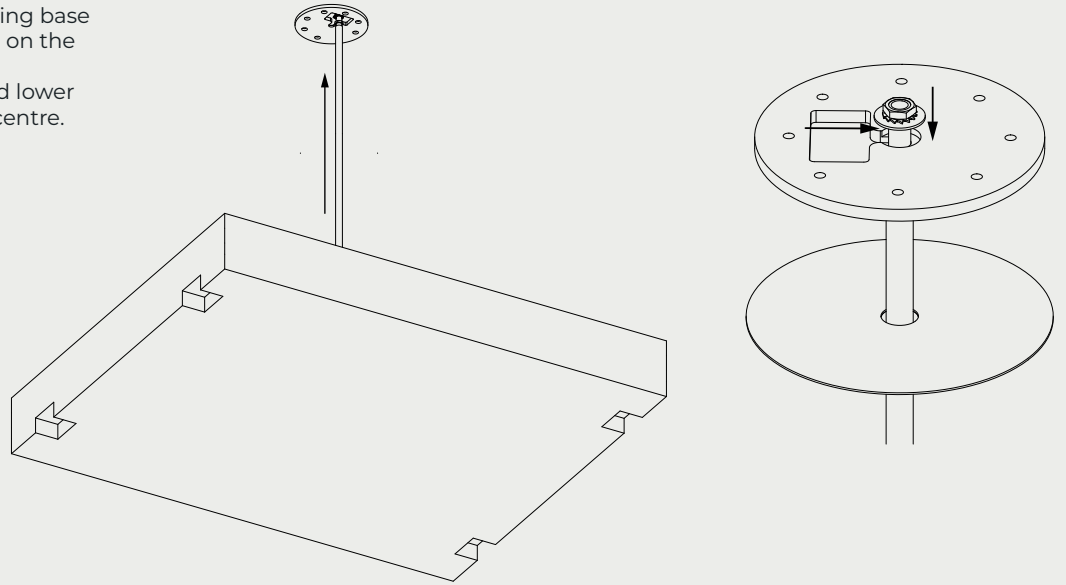

- 8.** Tighten the Nut below the flat plate to lock the pendant in place.
Then remove the packaging base.

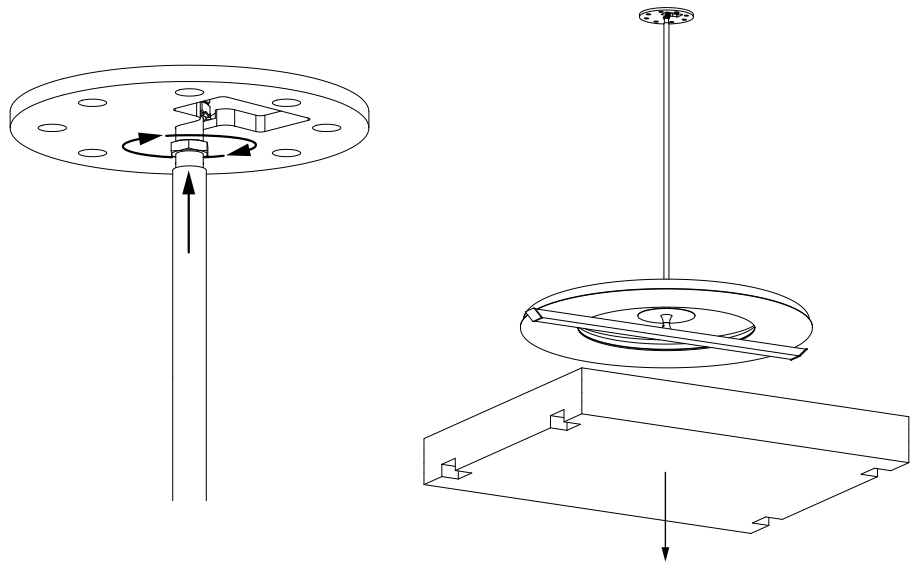

- 9.** Lift the cover plate up to the flush ceiling plate, then tighten in place using the grub screw in the collar

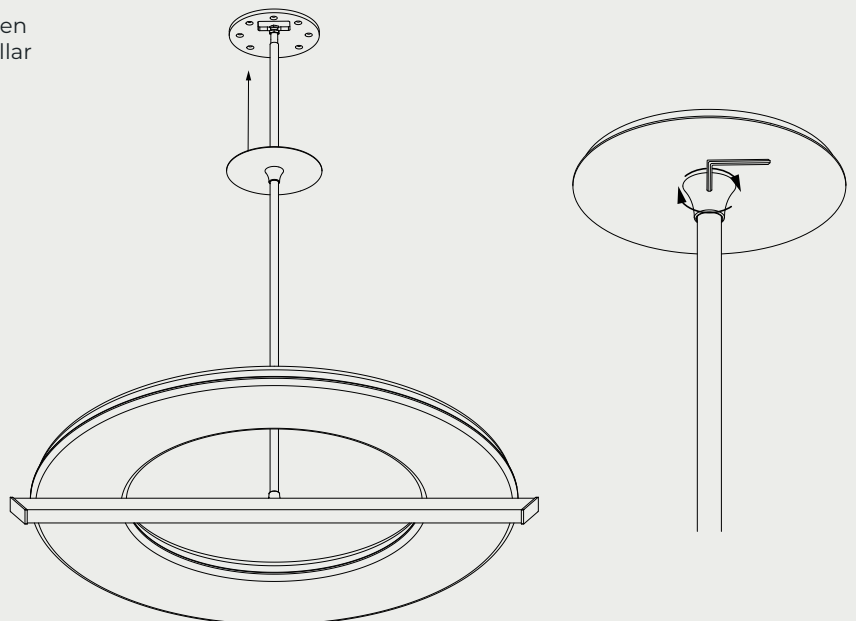

Ceiling Rose Installation

1. 230V

Fix the mounting plate to the ceiling using a suitable fixing method and plugs (Not Supplied)

110v

Fix the mounting plate to the junction box using suitable screws. Using additional fixings to the ceiling.

230v

110v

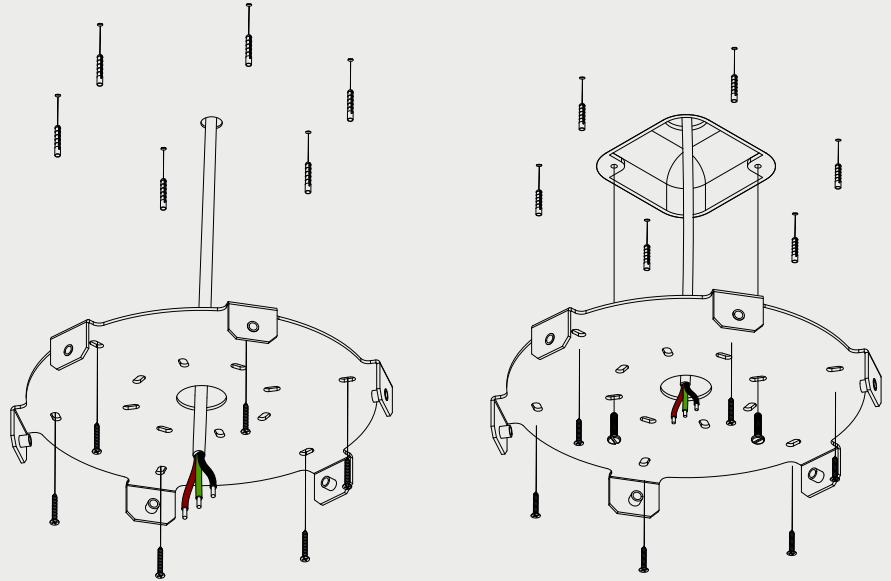

2. A. Feed the cables through then tighten the drop rod (B) into the centre of the Ring (A).

B. Then tighten the 4 grub screws at the base of the drop rod to lock it in place.

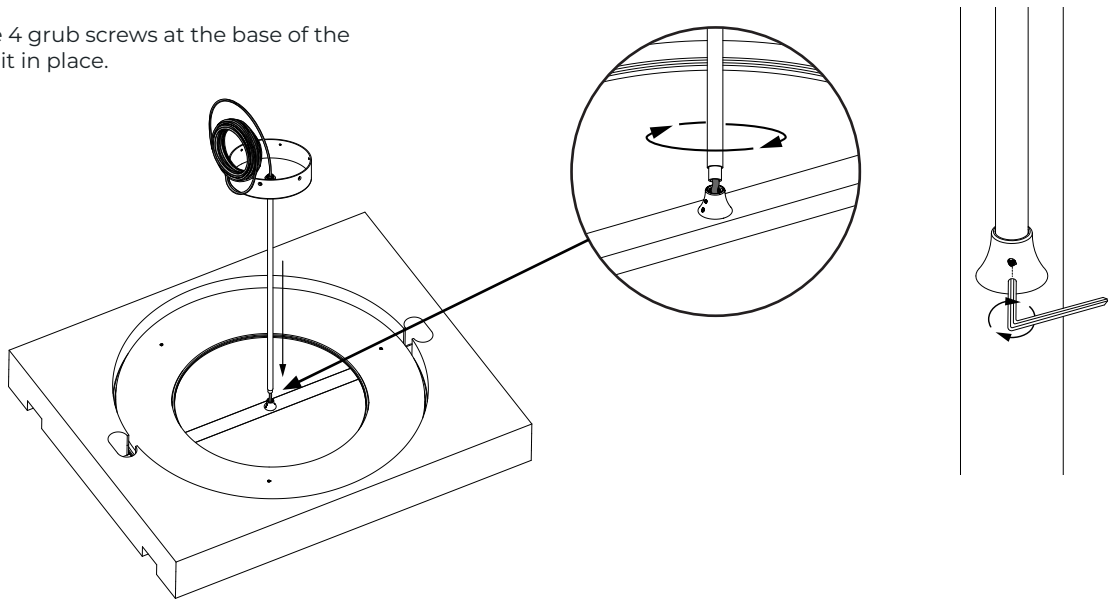

3. Raise the pendant in the packaging base and make the electrical connections inside the ceiling box ensuring all wires are colour matched and the pendant is earthed correctly.

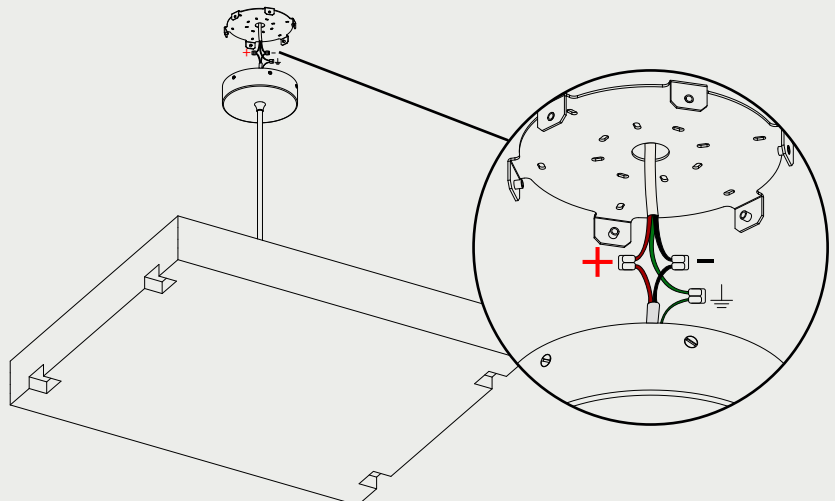
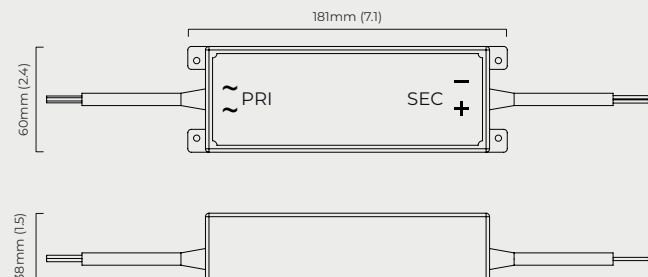

4. Fix the pendant to the ceiling bracket using the 6 screws provided.

Then Remove from the packaging.

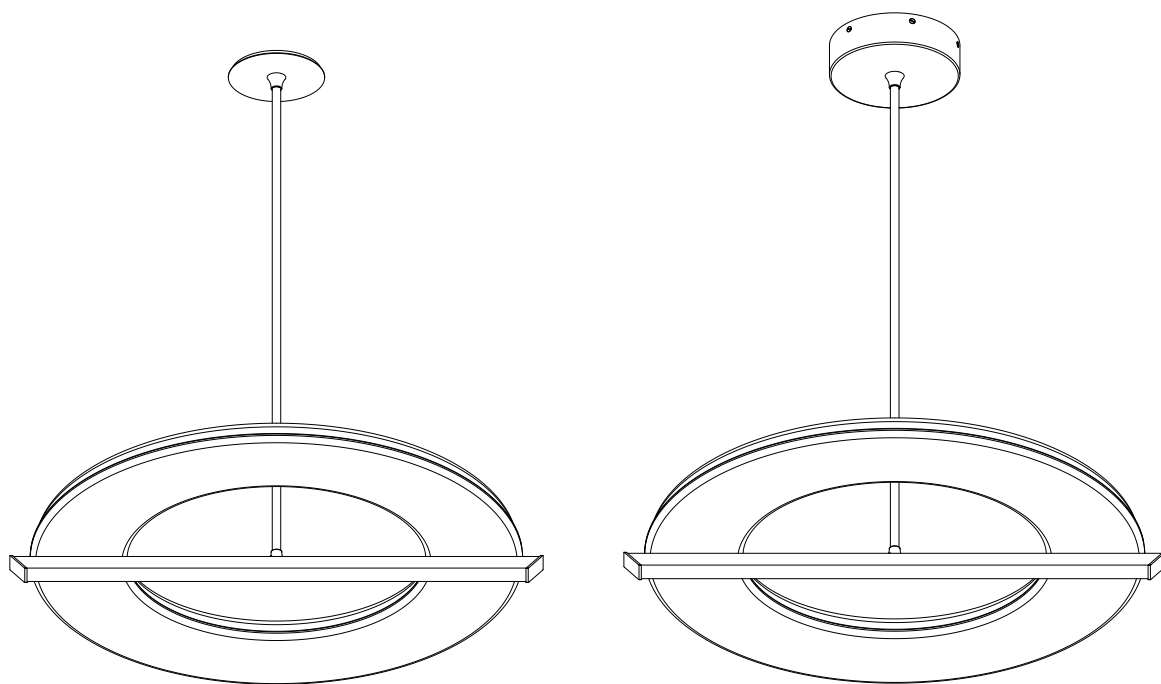
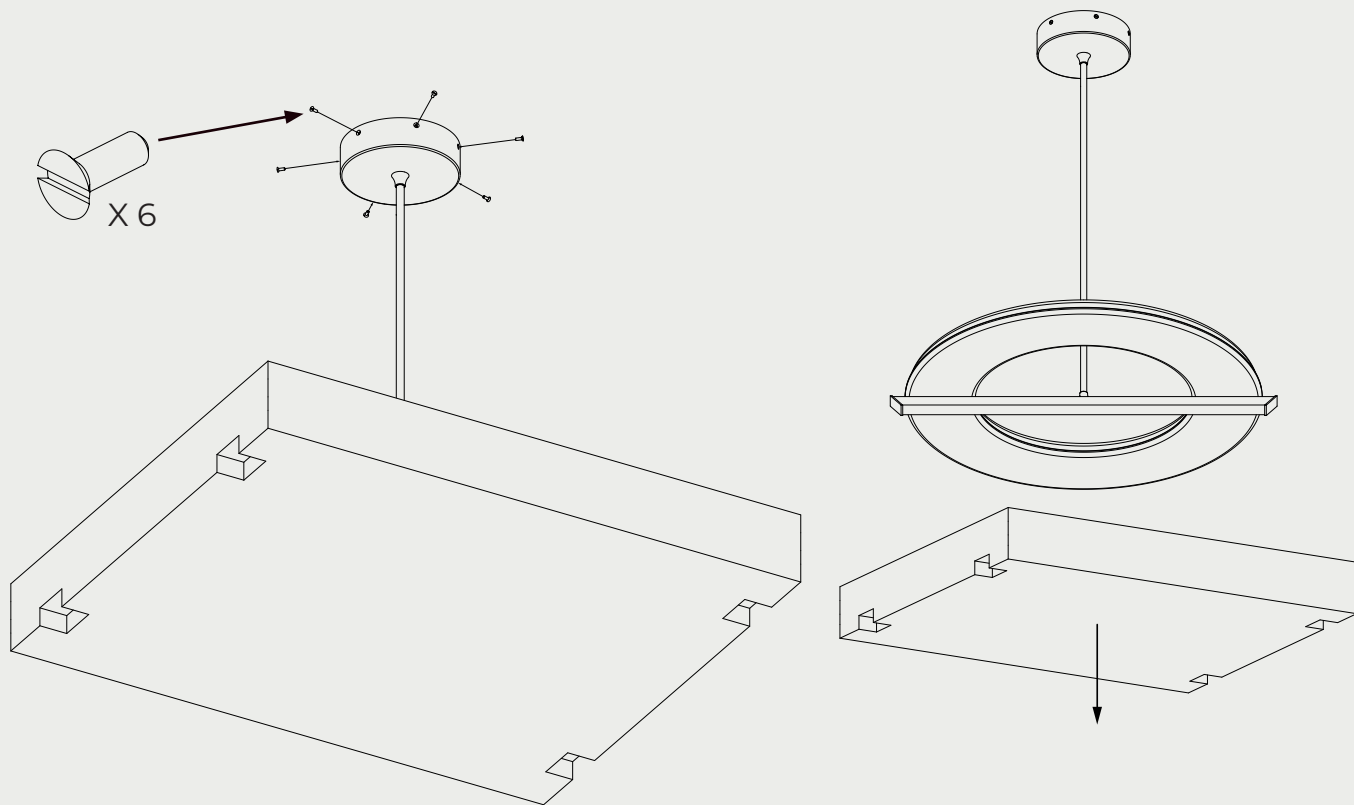

MAINTENANCE

Cleaning

Dust using a dry lint-free cloth weekly or as required

Repairs

Contact
CTO Lighting

Warranty

Please visit
ctolighting.co.uk/pages/f-a-q
For CTO warranty policy

Certification

CE UK
CA IP20